

# Modulating digital controller for heating and **cooling**



01122/08 GB  
replaces dp 01122/05

## 161 series



BSI EN ISO 9001:2000  
Cert. n° FM 21654



UNI EN ISO 9001:2000  
Cert. n° 0003



### Function

The controller can be used with three-point motorized mixing valves with rotation times ranging between 30 and 240 seconds. It performs **both set point and modulating regulation**. In the modulating mode, **the controller automatically varies the flow temperature depending on the actual value of the system return temperature**. This is detected to indicate the instantaneous ambient load. This reduces system operating times and power overloads.

The controller is equipped with flow and return temperature probes and a wiring box for an easy use when mounted on the wall. It can also be connected from the back by means of a standard recessed electrical box.



### Product range

- Code **161000** Modulating digital controller for heating and **cooling**, with flow/return probes and contact probe holder
- Code **150050** Max. relative humidity probe
- Code **150051** Converter
- Code **150052** Transformer

### Technical specifications

#### Controller

- Three point type
- Electric supply: 230 V - 50 Hz
- Protection class: IP 40
- Control temperature range: 7-78°C

#### Flow/return temperature probes

- NTC type
- Control range: -10-125°C
- Time constant: 2,5 s
- Response: 10.000 Ω at 25°C
- Beta value: 25/85°C 3977 ±1,5%
- Two-wire cable with connection: 1/8" M
- Cable length: 1 m

### Dimensions

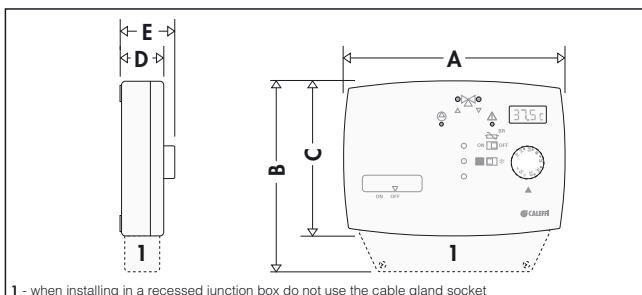

1 - when installing in a recessed junction box do not use the cable gland socket

Code	A	B	C	D	E	Weight (kg)
161000	133	129	90	35	42	0,31

### Relative humidity control components (optional)

#### Max. relative humidity probe

- Electric supply: 24 V - 50 Hz
- RH% limit: 80-85%

#### Converter

- Electric supply: 24 V - 50 Hz
- Microswitch contact rating: 6 / (2) A (230 V)
- Max. ambient temperature: 50°C
- DIN bar clamps

#### Transformer

- Electric supply: 230 V - 50 Hz
- Power consumption: 10,5 VA
- Max. ambient temperature: 50°C
- DIN bar clamps

### Dimensions

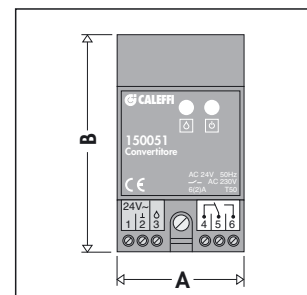

Code	A	B	Weight (kg)
150051	54	89	0,12

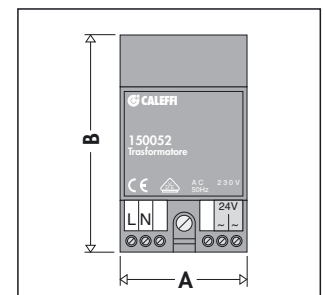

Code	A	B	Weight (kg)
150052	54	89	0,38

## Digital controller

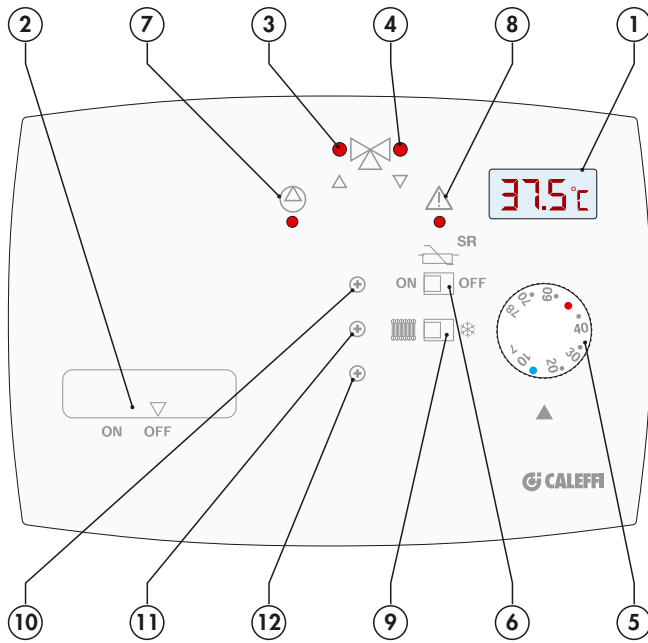

The front panel contains the following functions:

- 1) Three-digit LCD showing: measured or calculated temperature and settings of the delays programmed in the system.
  - Temperature range displayed: 0–99°C with 0,1°C resolution.
- 2) Controller function selector ON/OFF.
- 3) Mixing valve on opening: LED on.
- 4) Mixing valve on closing: LED on.
- 5) Selector for setting flow temperature.
  - Temperature range 7–78°C
  - Factory setting:
    - heating: max. 50°C
    - cooling: min. 14°C
- 6) Return probe switch.
  - Probe off: OFF
  - Probe on: ON
  - Factory setting: **ON**
- 7) Pump operating (ON): LED permanently on.
- 8) S.T. LED safety temperature. Continuously ON when the limit indicated by the safety thermostat or [safety humidostat is reached](#). Also continuously ON in case of flow/return probe malfunction (see flow/return probe paragraph).
- 9) Heating/cooling function exchange switch
- 10) Trimmer for maximum impulse duration on the valve. Adjustable 0,2–6 s. Factory setting: 2,5 s. Calculation of impulse value:
 
$$T_{\text{pulse}} \text{ (s)} = \frac{\text{Rotation time of actuator (s)}}{40}$$

Example:

$$T_{\text{actuator rotation}} = 120 \text{ s}$$

$$T_{\text{pulse}} = 120/40 = 3 \text{ s}$$
- 11) Trimmer for time delay in reading return probe. Adjustable 1–360 s. Factory setting: 20 s.
- 12) Trimmer of valve-motor mechanical delay recover. Adjustable 1–30 s. Factory setting: 5 s.

## Operating principle

The controller receives the activation signal from the ambient thermostat to start the pump and operate the mixing valve. The controller operates the mixing valve according to two logic approaches, depending on whether the return probe is on or off.

**Set point regulation:** return probe off. Selector 6) OFF.

In this case the flow temperature FT is held constant at the value set using the selector 5) for both heating and [cooling](#). The setting is shown on the display 1).

**Modulating regulation:** return probe on. Selector 6) ON.

In this case the flow temperature FT is modified as a function of the temperature measured by the return probe RT. This keeps under control the actual thermal efficiency of the slab and as a consequence the ambient thermal load. This thermal response time of the system is thus reduced to a minimum.

$$RT_{\text{set}} = FT_{\text{set}} - 35\% (FT_{\text{set}} - 20^\circ\text{C})$$

$$FT_{\text{calculated}} = FT_{\text{set}} + (RT_{\text{set}} - RT)$$

Example:

$$FT_{\text{set}} = 40^\circ\text{C}$$

$$RT_{\text{set}} = 40 - 0,35 \cdot (40 - 20) = 33^\circ\text{C}$$

$$FT_{\text{calculated}} = 40 + (33 - RT)$$

The new FT value calculated is shown on the display 1) highlighted a side bar.



Each time the FT is calculated, the measured FT is displayed for 5 s, after which the new calculated FT is shown.

Changes to FT stop when the RT reaches the  $RT_{\text{set}}$ .

[The return probe is switched off during the cooling function.](#)

## Curve correction with return probe

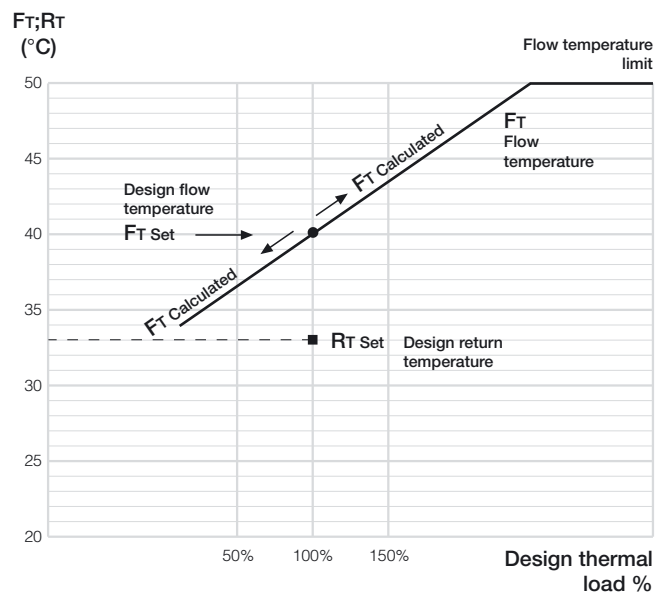

## Display

The three-digit LCD display shows the following parameters:

- Flow temperature set using the selector 5). The flow temperature measured appears after 5 s.
- Measured flow temperature, with return probe off.
- Calculated flow temperature, with return probe on.
- Maximum duration of the impulse on the valve, selected using the trimmer 10). Displayed for 5 s.
- Delay time for acquiring the return temperature, selected using the trimmer 11). Displayed for 5 s.
- Valve-motor mechanical delay recover, selected using the trimmer 12). Displayed for 5 s.

## Back panel

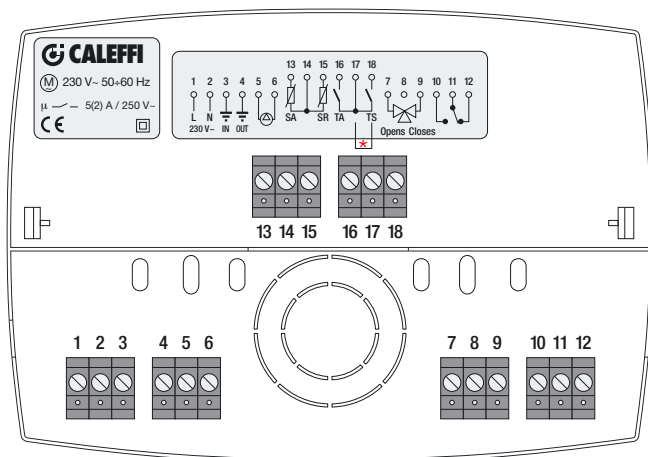

\*When there is a safety thermostat, eliminate the jumper

The terminals for the various electrical connections are located on the back panel.

### Electric supply

- 1 Supply 230 V~ "Live"
- 2 Supply 230 V~ "Neutral"
- 3 Ground/Earth

### Pump control

- 4 Ground/Earth
- 5 Pump control 230 V~ "Live"
- 6 Pump control 230 V~ "Neutral"

### Mixing valve control (TRIAC: contact rating 1 A (230 V))

- 7 Valve control on opening
- 8 Common C
- 9 Valve control on closing

### Auxiliary microswitch (contact rating relay 5 / (2) A)

- 10 Auxiliary outlet N/O
- 11 Auxiliary common outlet C
- 12 Auxiliary outlet N/C

### Flow/return probe

- 13 Flow temperature probe
- 14 Common C
- 15 Return temperature probe

### Ambient thermostat/safety thermostat

- 16 Ambient thermostat contact
- 17 Common C contact for ambient thermostat / common C contact for safety thermostat and [humidity probe converter](#)
- 18 Contact for safety thermostat and [humidity probe converter](#).

## Heating safety thermostat

If the safety thermostat trips, on detecting a higher flow temperature than the setting, the following state comes into operation: pump OFF, mixing valve closed. The thermostat contact is N/C; if the connection is missing, the controller is off.

## Auxiliary microswitch

The controller is equipped with an auxiliary microswitch which can be used to control other equipments.

Example:

For Heating, to switch the boiler on or off.

N/O contact - Pump off - ambient thermostat OFF or safety thermostat on (boiler off).

N/C contact - Pump on - ambient thermostat ON (boiler on).

For Cooling, to switch the chiller unit on or off.

N/O contact - Pump off - ambient thermostat OFF or RH% limit probe on (chiller unit off).

N/C contact - Pump on - ambient thermostat ON (chiller unit on).

Contact rating: 5 / (2) A (230 V).

## Flow/return probe

The flow/return temperature probes are the NTC type. If the probes detect ohmic resistance indicating a short circuit, the following operating state is set:

pump OFF, mixing valve closed, LED 8) permanently on.

## Table of probe resistance values

°C	Ω	°C	Ω	°C	Ω	°C	Ω	°C	Ω
-20	97.060	10	19.903	40	5.327	70	1.752	100	680
-15	72.940	15	15.714	45	4.370	75	1.480	105	592
-10	55.319	20	12.493	50	3.603	80	1.255	110	517
-5	42.324	25	10.000	55	2.986	85	1.070	115	450
0	32.654	30	8.056	60	2.488	90	915	120	390
5	25.396	35	6.530	65	2.083	95	787	125	340

## Flow temperature limit for heating and cooling

Maximum heating and [minimum cooling flow temperatures can be set with the controller](#).

Dip switches are located on the bottom of the controller in order to set different limit temperatures.

Factory setting:   
 - heating max. 50°C   
 - cooling min. 14°C

Table of limit temperature-dip switch positions

Dip switch setting			Maximum Limit	Minimum Limit
0	0	0	50	14
0	0	1	54	13
0	1	0	58	12
0	1	1	62	11
1	0	0	66	10
1	0	1	70	9
1	1	0	74	8
1	1	1	78	7

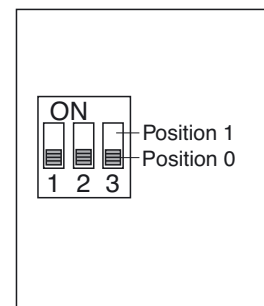

## Maximum cooling temperature limit

Cooling flow temperature cannot be set greater than 25°C.

### Control of relative humidity

When the controller is used for cooling, the relative humidity probe must be used. The function of this probe is to detect the maximum relative humidity limit in order to prevent the formation of condensation in the cooling slab.

It is set for RH = 80–85%. When this level is reached, the following operating state is set: pump ON, mixing valve closed.

### Connection of the humidity probe

The humidity probe is connected to the controller through a special transformer and converter.

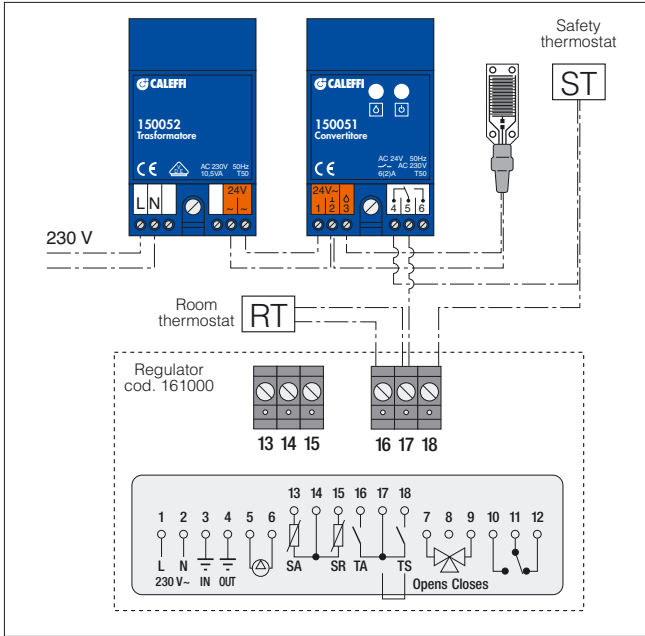

In order to control different zones that are at risk of condensation forming, the humidity probe should be connected to a special interface kit (transformer, converter and humidity probe). Up to 12 converters and probes can be connected to a single transformer.

### Example of connection with multiple sensors on different manifold:

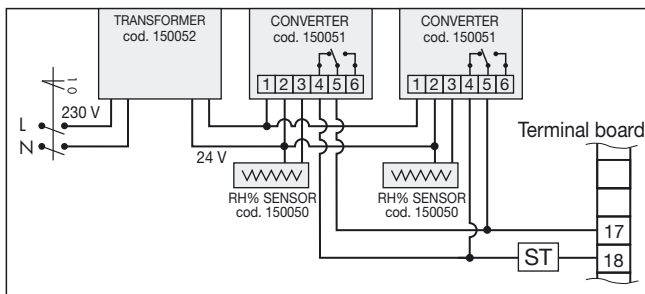

### Example of connection to different zone valves

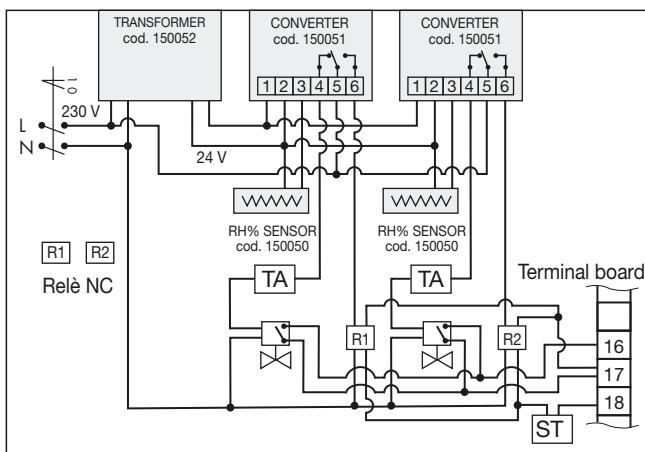

### Testing the humidity probe

The functioning of the probe must be checked at the start of each cooling season by placing a damp wad of cotton wool on the surface; this should cause the mixing valve to be switched off and switch on the red LED point 8 on the front of the control panel.

### Location of the humidity probe

The humidity probe is located at the point where humidity is most likely to form which will depend on the system design. It is positioned with the carbon printed surface facing upwards as in the following diagrams.

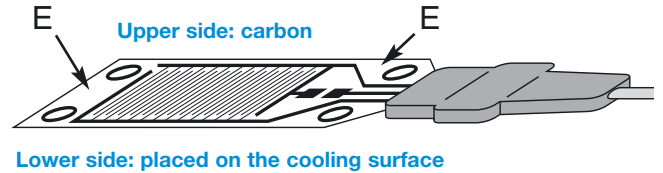

### Layouts for the correct positioning of the max RH% limit probe.

The probe should be fixed to the manifold installed in the zone where the RH% relative humidity has not to exceed the safety limits. Fix the probe by inserting the two straps through the holes.

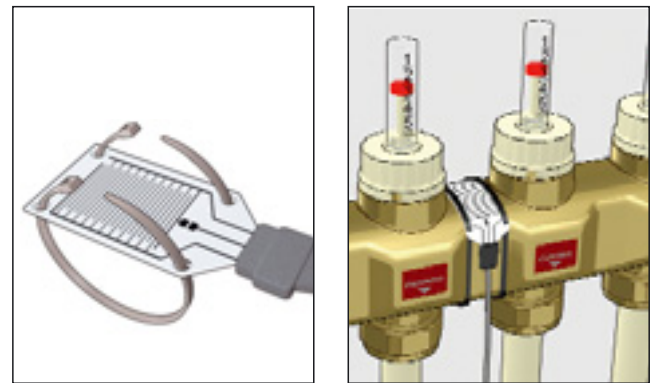

The maximum thermal energy that the panel can produce can be reached by controlling the parameters below.

- Minimum flow temperature can be set using the selector 5) on the front panel.
- Maximum relative humidity RH% limit, controlled through the relative humidity probe.
- Room temperature, controlled by the room thermostat
- Room temperature and relative humidity, controlled by a fan coil or dehumidifier.

**N.B.: The RH% limit probe is used to forestall any formation of condensation. In areas with cooling, adequate air treatment must always be present.**

### Accessories



**738**

Ambient digital chrono-thermostat, battery operated.

**With self-learning programme.**

Weekly programming.  
Suitable for phone programmer.  
Three temperature levels + antifreeze.  
Minimum programming: 30 minutes.  
Protection class. IP 30



Code

**738107** 124 x 90 x 21 mm

## Mixing valves



### 610

Three-way butterfly mixing valve, threaded connections.  
Max. working pressure: 6 bar.  
Working temperature range: 2–110°C.  
**Heavy series.**



Three-way butterfly mixing valve, flanged connections.  
Body PN 6.  
To be coupled with flat counterflange EN 1092-1.  
Max. working pressure: 6 bar.  
Working temperature range: 2–110°C.  
**Heavy series.**

## Hydraulic characteristics

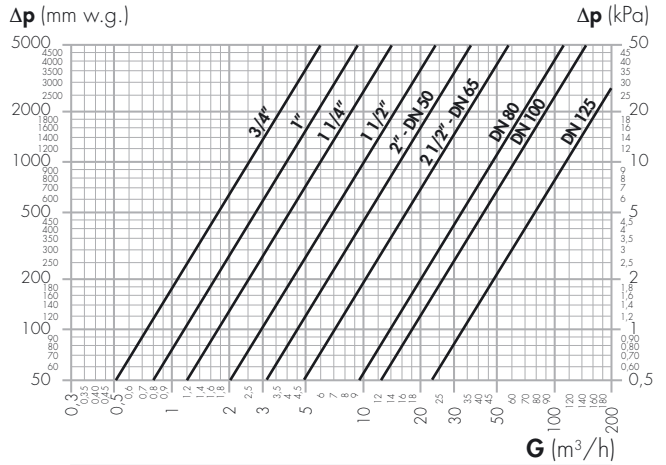

Ø	3/4"	1"	1 1/4"	1 1/2"	2"	2 1/2"
Kv (m³/h)	7.5	11.9	16.8	30	45	72
Ø	DN 50	DN 65	DN 80	DN 100	DN 125	
Kv (m³/h)	45	72	140	183	340	



### 611

Four-way butterfly mixing valve, threaded connections.  
Max. working pressure: 6 bar.  
Working temperature range: 2–110°C.  
**Heavy series.**



Four-way butterfly mixing valve, flanged connections.  
Body PN 6.  
To be coupled with flat counterflange EN 1092-1.  
Max. working pressure: 6 bar.  
Working temperature range: 2–110°C.  
**Heavy series.**

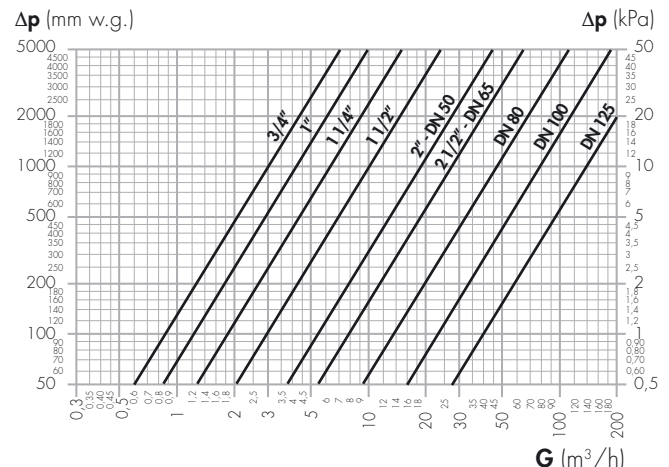

Ø	3/4"	1"	1 1/4"	1 1/2"	2"	2 1/2"
Kv (m³/h)	7.8	12.3	18.5	30	53	80
Ø	DN 50	DN 65	DN 80	DN 100	DN 125	
Kv (m³/h)	53	80	140	230	410	



### 612

Three-way sector mixing valve, threaded connections.  
Max. working pressure: 6 bar.  
Working temperature range: 2–110°C.  
**Heavy series.**



Three-way sector mixing valve, flanged connections.  
Body PN 6.  
To be coupled with flat counterflange EN 1092-1.  
Max. working pressure: 6 bar.  
Working temperature range: 2–110°C.  
**Heavy series.**

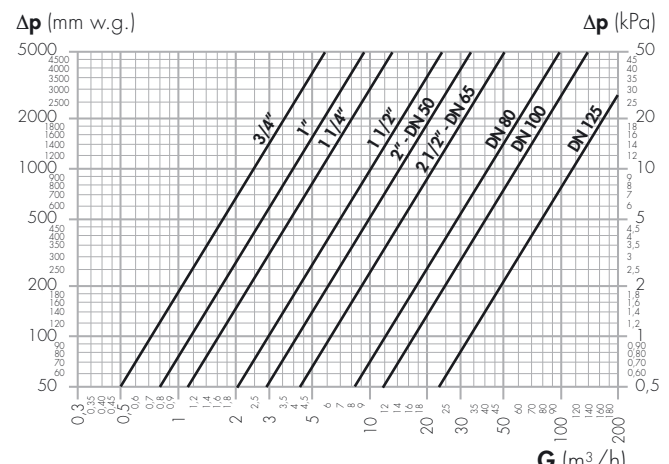

Ø	3/4"	1"	1 1/4"	1 1/2"	2"	2 1/2"
Kv (m³/h)	7.2	11.9	16.5	30	42	62
Ø	DN 50	DN 65	DN 80	DN 100	DN 125	
Kv (m³/h)	42	62	123	172	340	



## 6370

Actuator for mixing valves 610-611-612 series from 3/4" to 1 1/2".  
With adapter.  
**With auxiliary microswitch.**

### Technical specifications

Three point type	
Electric supply:	230 V (ac) or 24 V (ac)
Power consumption:	3 VA
Microswitch contact rating:	1 A (230 V)
Protection class:	IP 42
Operating time:	60 s (90° rotation)
Dynamic torque:	15 N·m



### Electric supply

- 1 = clockwise rotation (CW)
- 2 = counter clockwise rotation (CCW)
- 3 = common

### Auxiliary microswitch

- 4 = common
- 5 = N/C contact
- 6 = N/O contact

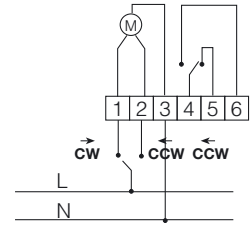

## 6370

Actuator for mixing valves 610-611-612 series from 2" to 5".  
With adapter.  
**With auxiliary microswitch.**

### Technical specifications

Three point type	
Electric supply:	230 V (ac) or 24 V (ac)
Power consumption:	4,5 VA
Microswitch contact rating:	1 A (230 V)
Protection class:	IP 42
Operating time:	180 s (90° rotation)
Dynamic torque:	35 N·m



### Electric supply

- 1 = clockwise rotation (CW)
- 2 = counter clockwise rotation (CCW)
- 3 = common

### Auxiliary microswitch

- 4 = common
- 5 = N/C contact
- 6 = N/O contact

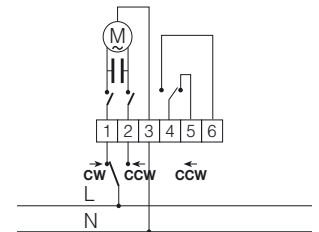

## 636

Three-way motorized piston valve, with manual opening.  
Full bore.  
**With auxiliary microswitch.**  
**The valve can be transformed into a two-way valve by blanking off the central third way.**

### Technical specifications

Three point type	
Electric supply:	230 V (ac) or 24 V (ac)
Max. working pressure:	16 bar
Max. working temperature:	110°C
Auxiliary microswitch contact rating:	3 A (230 V)
Protection class:	IP 44
Operating time:	90 s
$\Delta p$ max:	1 1/4", 1,2 bar; 1 1/2", 1 bar; 2", 0,9 bar



### Hydraulic characteristics

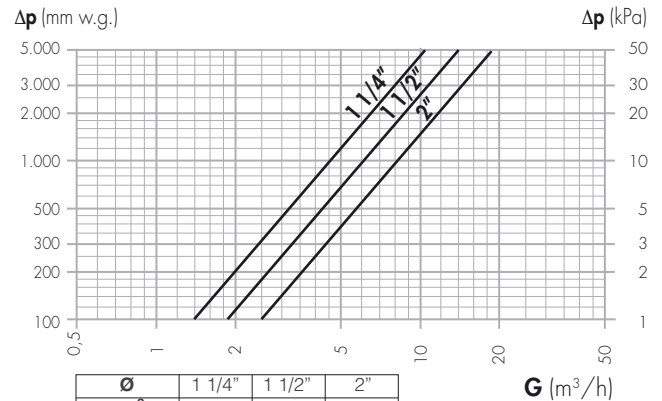

## 6371

Three-way motorized ball valve, with manual opening. "T" drilling, reduced bore.  
**With auxiliary microswitch.**

### Technical specifications





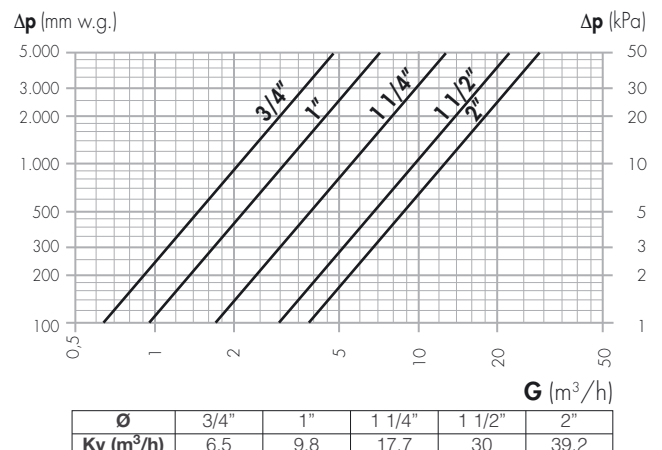

Three point type	
Electric supply:	230 V (ac) or 24 V (ac)
Max. working pressure:	40 bar
$\Delta p$ max:	6 bar
Working temperature range:	-10-100°C
Max. ambient temperature:	55°C
Power consumption:	3/4" and 1": 3 VA 1 1/4"-2": 5 VA
Auxiliary microswitch contact rating:	1 A (230 V)
Protection class:	IP 65
Operating time:	60 s (90° rotation)
Dynamic torque:	- 3/4" and 1": 15 N·m - 1 1/4"- 2": 20 N·m



### Hydraulic characteristics



# Application diagram

-  Shut-off valve
-  Pump
-  Temperature probe
-  Pressure gauge
-  Temperature gauge
-  Safety thermostat
-  Differential by-pass valve

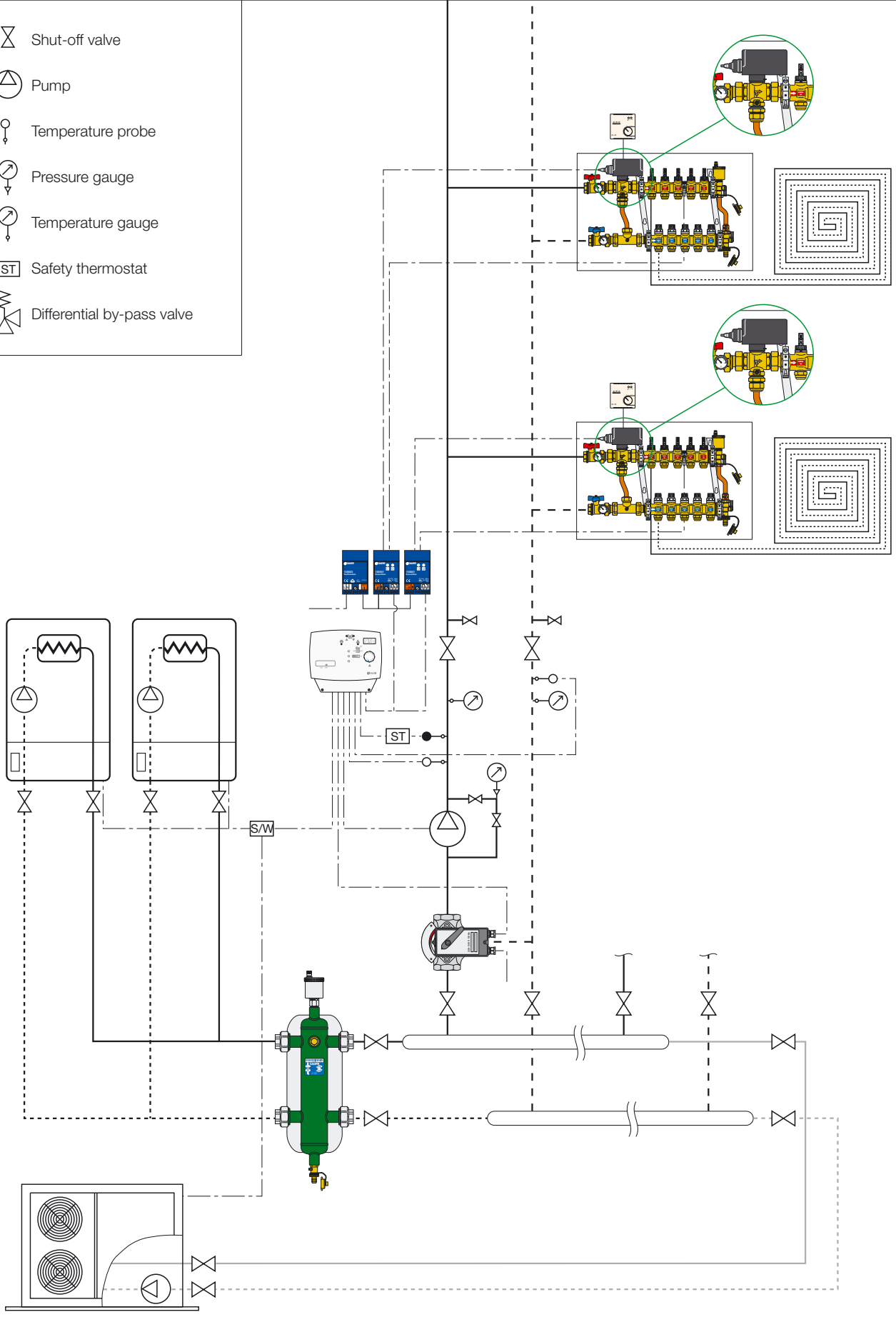

## SPECIFICATION SUMMARIES

### Code 161000

Modulating digital controller for heating and cooling. Complete with flow/return probes and contact probe holder. Three point type. Electric supply 230 V - 50 Hz. Protection class IP 40. Control temperature range 7–78°C. Complete with NTC flow/return probes. Working temperature range -10–125°C. Time constant 2,5 s. Response 10.000 Ω at 25°C. Beta value 25/85°C 3977 ±1,5%. Two-wire cable with 1/8" M connection, length 1 m.

### Code 150050

Maximum relative humidity probe. Electric supply 24 V – 50 Hz. RH% limit: 80–85%.

### Code 150051

Converter. Electric supply: 24 V - 50 Hz. Microswitch contact rating (TRIAC) 1 A (230 V). Maximum ambient temperature 50°C. DIN bar clamps.

### Code 150052

Transformer. Electric supply 230 V - 50 Hz. Power consumption 10,5 VA. Maximum ambient temperature 50°C. DIN bar clamps.

### 610 series

Three-way butterfly mixing valve with manual control. Heavy series. Threaded 3/4" F connections (3/4"-2 1/2"). Cast iron body and rotor. Aluminium cover and handle. NBR seals. Working temperature range 2–110°C. Maximum working pressure 6 bar. Can be motorized.

### 610 series

Three-way butterfly mixing valve with manual control. Heavy series. Flanged DN 50 connections (from DN 50 to DN 125). To be coupled with counterflange EN 1092-1. Cast iron body and rotor. Aluminium cover and handle. NBR seals. Working temperature range 2–110°C. Maximum working pressure 6 bar. Can be motorized.

### 611 series

Four-way butterfly mixing valve with manual control. Heavy series. Threaded 3/4" F connections (3/4"-2 1/2"). Cast iron body and rotor. Aluminium cover and handle. NBR seals. Working temperature range 2–110°C. Maximum working pressure 6 bar. Can be motorized.

### 611 series

Four-way butterfly mixing valve with manual control. Heavy series. Flanged DN 50 connections (DN 50–DN 125). To be coupled with counterflange EN 1092-1. Cast iron body and rotor. Aluminium cover and handle. NBR seals. Working temperature range 2–110°C. Maximum working pressure 6 bar. Can be motorized.

### 612 series

Three-way sector mixing valve with manual control. Heavy series. Threaded 3/4" F connections (3/4"-2 1/2"). Cast iron body and rotor. Aluminium cover and handle. NBR seals. Working temperature range 2–110°C. Maximum working pressure 6 bar. Can be motorized.

### 612 series

Three-way sector mixing valve with manual control. Heavy series. Flanged DN 50 connections (from DN 50 to DN 125). To be coupled with counterflange EN 1092-1. Cast iron body and rotor. Aluminium cover and handle. NBR seals. Working temperature range 2–110°C. Maximum working pressure 6 bar. Can be motorized.

### 636 series

Three-way motorized piston valve. Three-way with manual opening. Full bore. 1 1/4" F connections (from 1 1/4" to 2"). Brass body. Stainless steel stem. Self-extinguishing ABS motor cover. Maximum working pressure 16 bar. Maximum working temperature 110°C. Three point type actuator. Electric supply 230 V (ac) or 24 V (ac). Power consumption 3,7 VA. Operating time 90 seconds. Protection class IP 44. Maximum ambient temperature 50°C. Auxiliary microswitch contact rating 3 A (230 V).

### 637 series

Three-way motorized zone ball valve with manual opening and "T" drilling. Threaded 3/4" F connections (from 3/4" to 2"). Nickled brass body and ball. PTFE seals. Working temperature range -10–100 °C. Maximum working pressure 40 bar. Maximum differential pressure 6 bar. Actuator: Electric supply 230 V (ac) or 24 V (ac). Power consumption 3 VA (3/4"-1"); 5 VA (1 1/4"-2"). Dynamic torque 15 N·m (3/4" and 1": 15 N·m - 1 1/4"-2": 20 N·m). Operating time 60 seconds (rotation 90°). Protection class IP 65. Maximum ambient temperature 55°C. Auxiliary microswitch contact rating 1 A.

### 6370 series

Actuator for mixing valves from 3/4" (from 3/4" to 5"). Three point type regulation. Electric supply 230 V (ac) or 24 V (ac). Power consumption 3 VA (3/4"-1 1/2"); 4,5 VA (2"-5"). Dynamic torque 15 N·m (3/4"-1 1/2": 15 N·m - 2"-5": 35 N·m). Operating time 60 seconds (3/4"-1 1/2": 60 s, 2"-5": 180 s). Protection class IP 42. Maximum ambient temperature 50°C. Auxiliary microswitch contact rating 1 A.

*We reserve the right to make changes and improvements to the products and related data in this publication, at any time and without prior notice*



CALEFFI S.P.A. · I · 28010 FONTANETO D'AGOGNA (NO) · S.R. 229, N.25 · TEL. +39 0322 8491 R.A. · FAX +39 0322 863723

· [www.caleffi.com](http://www.caleffi.com) · [info@caleffi.com](mailto:info@caleffi.com) ·

© Copyright 2008 Caleffi